



Bonneagar Iompair Éireann
Transport Infrastructure Ireland

TII Publications



Guidelines for the Protection and Preservation of Trees, Hedgerows and Scrub Prior to, During and Post Construction of National Road Schemes

GE-ENV-01110

2006

About TII

Transport Infrastructure Ireland (TII) is responsible for managing and improving the country's national road and light rail networks.

About TII Publications

TII maintains an online suite of technical publications, which is managed through the TII Publications website. The contents of TII Publications is clearly split into 'Standards' and 'Technical' documentation. All documentation for implementation on TII schemes is collectively referred to as TII Publications (Standards), and all other documentation within the system is collectively referred to as TII Publications (Technical).

Document Attributes

Each document within TII Publications has a range of attributes associated with it, which allows for efficient access and retrieval of the document from the website. These attributes are also contained on the inside cover of each current document, for reference.

TII Publication Title	<i>Guidelines for the Protection and Preservation of Trees, Hedgerows and Scrub Prior to, During and Post Construction of National Road Schemes</i>
TII Publication Number	<i>GE-ENV-01110</i>

Activity	<i>General (GE)</i>	Document Set	<i>Technical</i>
Stream	<i>Environment (ENV)</i>	Publication Date	<i>2006</i>
Document Number	<i>01110</i>	Historical Reference	<i>N/A</i>

TII Publications Website

This document is part of the TII publications system all of which is available free of charge at <https://publications.tii.ie/>. For more information on the TII Publications system or to access further TII Publications documentation, please refer to the TII Publications website.

TII Authorisation and Contact Details

This document has been authorised by the Director of Professional Services, Transport Infrastructure Ireland. For any further guidance on the TII Publications system, please contact the following:

Contact: Standards and Research Section, Transport Infrastructure Ireland
 Postal Address: Parkgate Business Centre, Parkgate Street, Dublin 8, D08 DK10
 Telephone: +353 1 646 3600
 Email: infoPUBS@tii.ie

TRANSPORT INFRASTRUCTURE IRELAND (TII) PUBLICATIONS

This original document is part of a suite of documents published by the National Roads Authority (NRA) in the 2000s and early 2010s as part of its 'Four Stage Strategy – The Environmental Integration Model'. These documents were the NRA's *Environmental Assessment and Construction Guidelines* and *Guidelines for the Creation, Implementation and Maintenance of an Environmental Operating Plan*.

For further explanation on the 'Four Stage Strategy – The Environmental Integration Model,' refer to [TII Environmental Strategy](#) Section 4: *Delivery Framework*.

In some cases, these documents have been replaced by Transport Infrastructure Ireland (TII) with Standards and/or Technical Documents on TII's Publications system. In such cases, the original NRA environmental assessment or construction guideline is deemed to be withdrawn but is made available on TII's Publications system for historical reference (and, potentially, as a source reference in TII Standard and/or Technical Documents, where indicated).

Where original NRA *Environmental Assessment and Construction Guidelines* have not yet been replaced by newer TII Standards and/or Technical Documents, these are made available as Technical Documents, and they should continue to be consulted in the planning and construction of national road projects. However, given the passage of time, they should be read with a strong element of caution. These documents should be read in light of potentially significant changes in best practice, regulation, policy, etc., since original publication.



**GUIDELINES FOR
THE PROTECTION AND PRESERVATION OF
TREES, HEDGEROWS AND SCRUB PRIOR TO,
DURING AND POST CONSTRUCTION
OF NATIONAL ROAD SCHEMES**

ENVIRONMENTAL SERIES ON CONSTRUCTION IMPACTS

GUIDELINES FOR THE PROTECTION AND PRESERVATION OF TREES, HEDGEROWS AND SCRUB PRIOR TO, DURING AND POST CONSTRUCTION OF NATIONAL ROAD SCHEMES

INDEX

1	Introduction
3	Important Relevant Legislation
3	Statutory Restrictions on Vegetation Clearance
3	Tree Preservation Orders
3	Statutory Provisions in relation to Bats and Bat Roosts
4	The Biological Requirements of Trees
4	Potential Damage to Trees during Construction
4	Damage to the Root System
6	Structural damage of the Main Stem and Crown
7	Pre-Construction Work
7	Background
7	Incorporation of Protection into Design, Tender and Construction Phase
7	Pre-Construction Remedial Works and the Instalment of Protective measures
7	Tree Felling
7	Pruning and Crown Thinning
7	Barriers
8	Ground Protection
9	Protecting Trees During Construction
9	Tree Protection
9	Altering Ground Levels
10	Post Construction Monitoring
11	References

DISCLAIMER While every care has been taken to ensure that the content of this document is useful and accurate, the National Roads Authority and any contributing party shall have no legal responsibility for the content or the accuracy of the information so provided or for any loss or damage caused arising directly or indirectly in connection with reliance on the use of such information.

INTRODUCTION

This guidance document forms part of the National Roads Authority's (NRA's) Series of Environmental Assessment and Construction Guidelines. These particular guidelines should be read in conjunction with relevant NRA Guidelines and, in particular, they should be read having regard to:

- *Guidelines for Assessment of Ecological Impacts on National Road Schemes* (Rev. 1, National Roads Authority, 2006);
- *A Guide to Landscape Treatments for National Road Schemes* (National Roads Authority, 2006);
- *Best Practice Guidelines for the Conservation of Bats in the Planning of National Roads Schemes* (National Roads Authority, 2005); and,
- *Guidelines for the Treatment of Bats during the Construction of National Roads Schemes* (National Roads Authority, 2005).

This document provides guidance on the principles and measures to be adopted in affording protection and preservation to trees that are to be retained within or border the land-take of new national roads schemes.

Healthy, viable trees can play an important role in providing screening, and in some situations contribute to the reduction of traffic noise levels and concentrations of airborne pollutants. Trees can also help to visually soften the impact of roadway construction on the surrounding landscape as well as offering a valuable habitat for wildlife.

During the planning phase of national road schemes, every effort will have been made to minimize the number of trees and hedgerows that have to be removed as part of the scheme.

Trees may have been retained in situations where the land-take includes areas of severance identified for screening, landscaping, compensatory planting, or similar purposes. In addition, trees may have been retained at intersections where land-take exceeds that required for actual road construction. Such areas might include open areas within grade-separated junctions. However, when deciding upon trees to be retained during the Environmental Impact Assessment process, the preliminary designers will have ensured that the retention of trees does not impact on road safety or does not hinder the Contractor's scopes for innovative design or adversely affects the efficiency of the construction programme.

During the construction phase of national road schemes, lack of awareness of a tree's biological requirements can often result in irreversible damage, which could have been prevented through protective measures being put in place.

The protective measures required to avoid damage to trees during the construction phase as recommended in this document, are based on a comprehensive knowledge of the biological and physiological requirements of a tree. While these protective measures do not entail any significant expense, they do require an element of advance planning to be successfully implemented.

Trees, peripheral to the construction, but within the land-take and due for retention, may require specific treatment owing to altered ground levels and/or other close proximity works.

The Contractor, subject to the relevant statutory provisions, may sometimes establish site compounds on land outside of the CPO line. Where practicable, it is recommended that this guidance also be followed in relation to tree retention on these lands.

The tolerance of trees to disturbances may vary depending on the individual tree and species type. Such disturbances include:

- Mechanical damage to bark, limbs or roots;
- Compaction of the Root Protection Area (RPA) as the result of vehicular and pedestrian activity and/or the storage of materials within this area; and,
- Altered ground levels affecting the hydrological regime.

In most cases, such damage will result in the deterioration or death of the tree. Some species, such as beech, are particularly prone to even a minor alteration in ground level and healthy mature specimens can die within a few years of such disturbance.

Protection of trees and site quality are key aspects for proposed development sites. To assure tree quality, all tree parts must be protected from acute and chronic damage. Tree preservation should be based on an informed evaluation and application of best-practice arboricultural principals integrated into the planning and design stage.



Construction site impacting on mature trees.

Tree preservation should be based on an informed evaluation and application of best-practice arboricultural principals integrated into the planning and design stage.

IMPORTANT RELEVANT LEGISLATION

Particular regard should be had to the following legislation.

STATUTORY RESTRICTIONS ON VEGETATION CLEARANCE

Section 46(a) of the Wildlife (Amendment) Act 2000 makes it an offence **“for a person to cut, grub, burn or otherwise destroy, during the period beginning on the 1st day of March and ending on the 31st day of August in any year, any vegetation growing on any land not then cultivated.”** However, this requirement is waived for the purposes of roads construction. Notwithstanding this waiver, the Contractor should make reasonable efforts to avoid the felling of trees during the peak felling season from March to July.

TREE PRESERVATION ORDERS

Tree Preservation Orders (TPO) are made under Section 205 of the Planning and Development Act, 2000 where the Planning Authority considers it necessary in the interests of amenity or the environment to protect specific trees or woodlands. The appliance of a TPO is limited in practice and they are rarely encountered on national road schemes. Any TPO on or adjacent to a road scheme should be noted at the EIA stage by reference to the Planning Authority or the local development plan. If there is the potential to directly impact on a tree or group of trees protected by a TPO, immediate consultation with the Planning Authority should ensue.

With regard to trees not subject to a Tree Preservation Order, Section 37 (4) of the Forestry Act 1946 waives the requirement to issue Felling Notices where **“the tree is uprooted or cut down by a local authority in connection with roads construction or road widening or improvement schemes or construction works”**.

STATUTORY PROVISIONS IN RELATION TO BATS AND BAT ROOSTS

All bats, and trees that are identified as bat roosts, are afforded legal protection by the Wildlife Acts, 1976 and 2000, and the EU Habitats Directive (Under S.I. 94 of 1997). To proceed with the felling of these trees, it is necessary to obtain a licence from the National Parks and Wildlife Service.

When dealing with trees containing bat roosts, or having the potential to contain bat roosts, reference to the NRA's *Guidelines for the Treatment of Bats during the Construction of National Roads Schemes* (National Roads Authority, 2005) and *Best Practice Guidelines for the Conservation of Bats in the Planning of National Roads Schemes* (National Roads Authority, 2006) is essential.

THE BIOLOGICAL REQUIREMENTS OF TREES

A healthy tree has adapted to and achieved equilibrium with the prevailing local conditions. The need for light, nutrients, water and drainage must be met and the tree will adapt its growth form to find an appropriate balance with these essential elements. The primary functions of a root system are anchorage, water and nutrient uptake, and as a carbohydrate store. The root system will often radiate beyond the crown spread of the tree, primarily within the

top 600mm of soil. The main structural roots are typically close to the base of the trunk. The network of smaller feeder roots, which support the fine root hairs responsible for the uptake of water and nutrients, extend often asymmetrically from the trunk in response to the local conditions. Construction activity must take these essential requirements into account.

POTENTIAL DAMAGE TO TREES DURING CONSTRUCTION

DAMAGE TO THE ROOT SYSTEM

As a tree's root system is not visible it will often suffer damage which is frequently ignored. Damage to the root system will affect the long-term health, balance, growth and life expectancy of a tree. The effects of such damage may only become evident several years after construction.

Damage to a tree's root system can arise from a number of activities including:

- **Compaction of the Root Protection Area (RPA):** This may occur as the result of vehicular and pedestrian activity and/or the storage of materials within this area. This may be particularly the case in clayey soils;
- **Alteration of ground levels around the tree:** Damage may even occur from the temporary raising and lowering of the soil level;
- **Covering the soil around the tree with an impervious layer;**
- **The release of materials that are toxic to plants; and,**
- **Physical severance of structural roots.**

Trees respire through their root system and foliage. This respiration involves the intake of oxygen and the emission of carbon dioxide. The resulting diffusion through the soil maintains the balance between these gases which is fundamental to soil invertebrate respiration. Many

construction activities can result in changes to soil properties. In particular, alteration to the bulk density of the soil/compaction changes can be extremely damaging. Compacted sites generally do not support vigorous tree growth and construction site soils can easily have 50% greater bulk density than native soils. Increasing bulk density by one third can be expected to cost a tree one-half of its root and shoot growth. As the root system is primarily confined to the top 600mm of soil, any reduction in the capacity of this layer due to the compaction of the soil to hold or diffuse gases can result in the asphyxiation of the roots. This in turn can stress the tree possibly leading to its mortality.

Soil fills that raise the grade around trees are harmful: they disrupt aeration, water movement and reduce oxygen levels all resulting in root growth problems. While trees can tolerate slight grade changes, any grade change greater than 75mm can have negative impacts on the tree's long-term health. Where grade changes greater than 75mm cannot be avoided, porous soils, such as a sandy loam, should be used as fill material.

Various aeration systems have been used in the past in an attempt to improve soil aeration after raising the soil. However, aeration systems are expensive and, to date, there is no scientific evidence that they have a positive effect on the tree.

Similarly soil levels should not be greatly lowered around the root system so as to expose them to external elements. This may cause the roots to desiccate, potentially compromising the stability of the tree.

Hard surfacing (due to its low permeability and associated compaction) within the RPA of a tree can lead to asphyxiation. Where the use of hard surfacing is unavoidable, the surfaces should, where possible, slope away from the tree to avoid pooling of water around its base. Provisions should be made to allow for potential future growth if hard surfacing is proposed around the base of a tree.

Asphyxiation may also result if water levels are altered around the base of a tree.

Excavation works within the RPA can lead to physical damage of the root system. Stripping of topsoil can remove the majority of a tree's feeding roots, while

trenching may affect the stability of a tree by severance of the main anchor roots. In circumstances where such damage has occurred to a retained tree, the tree should be surveyed to assess the scale of the impact and the effect on the tree's structural stability.

The leakage or spillage of materials such as hydrocarbons, sewage effluent, cement and chemicals will damage root systems. Therefore, the storage of such materials and cement wash out areas should be located at least 10m from any retained tree. Storage tanks should have secondary containment provided by means of an above ground bund to capture any leakage or spillage. Bund specification should conform to the current best practice for oil storage (see Best Practice Guide BPGCS005 Oil Storage Guidelines (Enterprise Ireland)).

Increasing bulk density by one third can be expected to cost a tree one-half of its root and shoot growth.



Oak with ground levels radically lowered exposing root system.

STRUCTURAL DAMAGE OF THE MAIN STEM AND CROWN

Damage to the main stem and crown of a tree can occur due to physical damage caused by machinery. Damage can include branches being broken off or the main stem losing its protective bark. The bark of a tree forms a protective layer around the conducting tissues located immediately beneath. Extensive damage to the bark can indirectly lead to severe decline or mortality of the tree as it can render the tree susceptible to infection by fungi or bacteria.

The loss of limbs can alter the balance of the crown and result in the tree becoming susceptible to wind-throw.

Severance of areas of woodland, copses, tree-lines or hedgerows by a scheme may result in the removal of the protective edge trees and expose the inner trees. These inner trees may not have formed adequate root systems and exposure can lead to wind-throw. These trees may require specific pruning in order to reduce the risk of wind-throw. In such circumstances the advice of a qualified arborist should be sought. All pruning or surgery work should be carried out by qualified tree surgeons and in compliance with BS 3998 (1989) *Recommendations for tree work*.

The aerial parts of a tree are also susceptible to damage through inappropriately sited fires. Fires should not be lit in a position where the flames could extend to within 10m of any part of a tree.

The bark of a tree forms a protective layer around the conducting tissues located immediately beneath.



Scots pine showing damage to the trunk from construction works.



Unprotected tree. Note the storage of materials around the RPA. This tree will eventually succumb to the effect of soil compaction.



Tree displaying bark damage as a result of no protection. Possible entry point for pathogens.

PRE-CONSTRUCTION WORK

BACKGROUND

The EIA phase is the most crucial stage for the identification of protective measures required for the protection and preservation of trees that are designated for retention during the construction phase.

In evaluating trees to be retained during the EIA/Preliminary Design phase, the designers should have employed good arboricultural management methodologies. Recognition should have been given to the fact that all trees may not be suitable for retention due to their condition, age, species and location within the development. Inappropriate retention can affect a Contractor's ability to design innovatively and construct efficiently.

INCORPORATION OF PROTECTION INTO DESIGN, TENDER AND CONSTRUCTION PHASE

The schedule of trees for retention within the EIS will be incorporated into the Employer's Requirements. Adequate provisions will have been made within the tender submissions for the incorporation of protective measures for scheduled trees during the detailed design and construction phases.

PRE-CONSTRUCTION REMEDIAL WORKS AND THE INSTALMENT OF PROTECTIVE MEASURES

The instalment of protective measures and the undertaking of all remedial works should be carried out prior to commencement of any on site construction activity.

Any remedial works required to trees identified for retention should be carried out prior to construction by qualified tree surgeons in accordance with BS 3998 (1989) *Recommendations for tree work*.

TREE FELLING

In their negotiations with landowners prior to and during the CPO phase, the local authority will have made every effort to ensure that the landowner does not fell any trees on the land being acquired, whether they are scheduled for retention or not. This will avoid situations where landowners fell trees scheduled for retention or during inappropriate seasons.

PRUNING AND CROWN THINNING

Severance of woodland, copses or hedgerows requires sensitive treatment in order to avoid inadvertent damage to the remaining vegetation. A natural woodland edge will have a cambered profile that allows the wind to deflect over the woodland without generating strong resistance or eddies.

Where a block of woodland is severed, the profile of the woodland is altered and the trees now exposed will typically have unbalanced growth. This may be particularly pronounced in young un-managed woodland where closely grouped trees have developed spindly forms due to competition for light.

In order to reduce a woodland edge's susceptibility to wind damage, trees may often require formative pruning, crown thinning or reduction. This could be facilitated by the permanent or temporary acquisition of land or by other arrangements as appropriate.

Damage to adjacent trees or vegetation should be avoided, especially with regard to grubbing of roots or stumps of felled trees in a woodland environment where root systems are typically intertwined.

BARRIERS

Vertical barriers and/or ground protection must protect all trees that are being retained on site. It is essential that these provisions be put in place prior to any development work or soil excavations are carried out.

The purpose of protective barriers is to exclude any harmful construction activity that may damage the RPA. They also help protect the main stem of the tree.

Tree protection barriers should be fit for the purposes of excluding construction activities and be durable to withstand an impact. The barrier should consist of a vertical and horizontal frame and should be at least 2.3m in height (Ref to figure 1 as an example).

To ensure the protection barriers are respected, clear concise signage must be affixed to the barrier in an unrestricted easily viewed location. The signage must specify that no construction activity is to take place within the RPA. This should remain the case until completion of all works unless certain works are deemed acceptable following consultation with an arborist. The signage must also state that no materials of any description are to be stored or the “spilling out” of materials should not occur within the RPA. Site personnel must be made aware of the importance of the protective barrier.

An important point to remember prior to the design and installation of protective barriers, are that roots are often asymmetric so an arbitrarily chosen circular protection zone can often prove to be inadequate. Asymmetry of roots can be suspected if the ground is sloping to one side or if there are other variables restricting root development.

The extent of the RPA can be calculated as follows:

The following example is a calculation for a single stem tree:

$$RPA(m^2) = \pi \left(\frac{\text{stem diameter}(mm) \times 12}{1000} \right)^2$$

For multi-stem trees where the stems branch out below 1.5m measured immediately above the root flare (i.e. the basal diameter) the following calculation is used:

$$RPA(m^2) = \pi \left(\frac{\text{basal diameter}(mm) \times 10}{1000} \right)^2$$

GROUND PROTECTION

There are occasions when vehicular and pedestrian traffic will occur within the calculated RPA. In these circumstances and where it is feasible, the RPA should be protected with suitable ground protection.

For pedestrian activity within the RPA, adequate ground protection could be in the form of a layer of bark mulch spread to a thickness of approximately 100mm. Another alternative that may offer more appropriate protection is the use of single thickness scaffolding boards placed upon a layer of geotextile material (to allow water penetration). Pedestrian and vehicular activities should only take place within the RPA where necessary and should be kept to a minimum.

Where it is deemed absolutely necessary, a temporary buffer zone may be created which will allow medium sized vehicles to cross the RPA. The ground within the temporary buffer zone shall be covered by 25mm plywood sheets, layered upon 25mm of quarry gravel, layered upon 150mm of bark mulch. Steel plates can also be used.

The purpose of protective barriers is to exclude any harmful construction activity that may damage the RPA.

PROTECTING TREES DURING CONSTRUCTION

TREE PROTECTION

Following the implementation of all the necessary protective measures, trees remain vulnerable during construction. Consultations with a qualified arborist may be required during the development, as certain construction activities within the RPA are unavoidable, e.g., excavation work. Any excavation works carried out within the RPA should be undertaken with extreme care and should be carried out with due diligence, avoiding damage to the protective bark covering larger roots. This may involve excavation by mini-digger and/or hand as deemed appropriate. Exposed roots should be wrapped in a hessian sacking to avoid desiccation and roots less than 2.5cm in diameter can be pruned back to a side root. The advice of a qualified arborist should be sought if larger roots that influence anchorage need to be severed.

Trunk protection should also be put in place using hessian sacking and timber strips clad around the tree, in order to mitigate any potential damage that may occur.

ALTERING GROUND LEVELS

As previously outlined, alteration of ground levels within the RPA should only be carried out following a considered assessment of the likely impact on the tree. In general, a ground alteration in excess of 75mm should be avoided. Changes in ground levels in the vicinity of a tree may alter the existing soil hydrology and necessitate the incorporation of adequate drainage around the tree. New impermeable surfaces should not cover more than 20% of the RPA. An increase in ground level up to a maximum of 1m is tolerable for certain species using specific techniques (beech and oak are not amenable to such a level of disturbance). This involves the construction of a dry well around the tree trunk allowing for future growth and the incorporation of coarse aggregates to provide sufficient drainage and allow for gaseous diffusion in the raised ground.

POST CONSTRUCTION MONITORING

Depending on the type of contract, post-construction monitoring requirements should be stipulated in the Employer's Requirements or Maintenance Requirements for the local authorities.

Upon completion of the road construction, monitoring should be carried out to determine the success of the measures employed. Monitoring should be continued for at least one year after construction work ceases.

Any remedial works that need to be carried out must be undertaken by qualified tree surgeons. Certain cultural operations may be required such as irrigation of the tree's root system. In certain situations the application of a phosphorus-based fertilizer can be applied in order to assist in the stimulation of new feeder roots. Where compaction has occurred it can be alleviated by the use of compressed air injection. Once any remedial works are complete and all plant equipment has evacuated the site, protective barriers and ground protection can be removed.



An example of an unprotected tree where ground levels have been altered.

POST CONSTRUCTION MONITORING

Depending on the type of contract, post-construction monitoring requirements should be stipulated in the Employer's Requirements or Maintenance Requirements for the local authorities.

Upon completion of the road construction, monitoring should be carried out to determine the success of the measures employed. Monitoring should be continued for at least one year after construction work ceases.

Any remedial works that need to be carried out must be undertaken by qualified tree surgeons. Certain cultural

operations may be required such as irrigation of the tree's root system. In certain situations the application of a phosphorus-based fertilizer can be applied in order to assist in the stimulation of new feeder roots. Where compaction has occurred it can be alleviated by the use of compressed air injection. Once any remedial works are complete and all plant equipment has evacuated the site, protective barriers and ground protection can be removed.

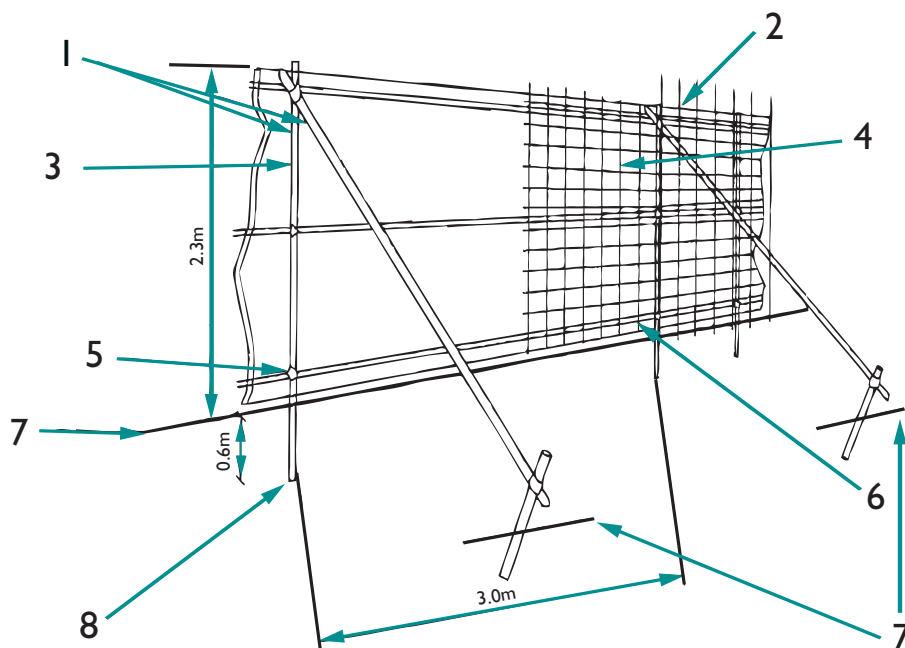

Figure 1. An example of a suitable protective barrier

1. Standard scaffold poles
2. Uprights to be driven into the ground
3. Panels secured to uprights with wire ties and where necessary scaffold poles
4. Weldmesh wired to the uprights and horizontals
5. Standard clamps
6. Wire twisted and secured on the inside of fencing to avoid easy dismantling
7. Ground level
8. Approx. 0.6m driven into the ground

REFERENCES

Matheny, N. and J. Clark (1998).

Trees and Development: A Technical Guide to Preservation of Trees During Land Development.
Champaign, IL: International Society of Arboriculture: 183.

National Roads Authority (2006).

Guidelines for Assessment of Ecological Impacts on National Road Schemes (Rev. 1, National Roads Authority
National Roads Authority, Dublin

National Roads Authority (2006).

A Guide to Landscape Treatments for National Road Schemes.
National Roads Authority, Dublin.

National Roads Authority (2006).

Best Practice Guidelines for the Conservation of Bats in the Planning of National Road Schemes.
National Roads Authority, Dublin.

National Roads Authority (2005).

Guidelines for the Treatment of Bats during the Construction of National Roads Schemes.
National Roads Authority, Dublin.

BS 5837 (2005): Trees in relation to Construction.

BS 3998 (1989): Recommendations for Tree Work.

GUIDELINES FOR
THE PROTECTION AND PRESERVATION OF
TREES, HEDGEROWS AND SCRUB PRIOR TO,
DURING AND POST CONSTRUCTION
OF NATIONAL ROAD SCHEMES



National Roads Authority
St Martin's House, Waterloo Road, Dublin 4
Tel: 01 6602511
Web: www.nra.ie

This document was prepared by Michael Garry, Arbor-Care, Unit 1a, Crossagalla Enterprise Centre, Ballysimon Rd, Limerick and NATURA Environmental Consultants, Enterprise Centre, Murrough, Wicklow in association with the National Roads Authority.





Ionad Ghnó Gheata na Páirce,
Stráid Gheata na Páirce,
Baile Átha Cliath 8, D08 DK10, Éire



www.tii.ie



+353 (01) 646 3600



Parkgate Business Centre,
Parkgate Street,
Dublin 8, D08 DK10, Ireland



info@tii.ie



+353 (01) 646 3601